

LDA800 is a complete solution dedicated to 1-way or 2-way self-powered loudspeakers. Designed to meet different applications, it provides 2 channels with output power of 2x800W@4 Ohm. Moreover the 2 channels can be bridged into a powerful single 1x1400W@4Ohm channel in order to drive i.e. Subwoofers or Multiple Ways Cabinets with Passive Xovers. In addition it offers a full set of added value features such as on board DSP and RS485 connection for monitoring and control via dedicated PC software. To guarantee maximum reliability, the **LDA800** includes a highly efficient universal switch mode power supply with PFC (Power Factor Correction) which provides a total 1400W power to the 2 output channels. The 2 output stages use the well-known Pascal Class D MPRO2 module. The **LDA800** includes a set of sophisticated processes for loudspeaker, implemented by the powerful M704 DSP running 96kHz/24bit [96 bits precision for the internal/intermediate processes] and high performance

AD/DA Converters. Processes as Noise Gate, crossover filters, parametric EQs per input and output sections, RMS compressor, alignment delay and All-Pass filters are available, all in all everything needed to optimize a self-powered loudspeaker. Moreover the Clip/Limiter function per channel provides output monitoring to prevent speaker damage with gentle gain reduction at clip threshold, in addition to the efficient heat dissipation system and Over-Heat protection which themselves ensure uncompromised reliability. Furthermore the **LDA800** is also equipped with a Dynamic Loudness function and an useful Pink/White noise generator. All setup parameters for input mixing, DSP features and the limiter setting are accessible by using the remote PC software. High Band can be split or not in two sub-band. When the Xover split freq is enabled then the RMS compressor working on the lower band and a additional volume (hi_level) working on the Higher band.



Features

Outstanding Performance

High power output: 2 x 800W @ 4Ω or 1 x 1400W @ 8Ω (Bridge Mode)

Switched-Mode Power Supply with PFC and auto voltage sensing

Pascal Class D Amp Module - full bandwidth PWM modulator with ultra low distortion

Full protection circuitry including Over-Current, Over/Under-Voltage, Output DC and Over-Temperature

Excellent sonic performance with 24bit high end converters coupled with 96kHz sample rate

Top-grade DSP Engine

5 band parametric equalization per input channel

7 band parametric equalization per output channels

2 filter can be switched to Bell, Low/High Shelving, per channel

Low/High Shelving, can be selected as variable Q response

Crossover filters with slopes from 6dB/Octave up to -48dB/Octave including Butterworth, Bessel, Linkwitz-Riley

Output features a precision dynamic range controller composed of a RMS Compressor with selectable ratio and variable knee

Input features a precision dynamic range controller composed of a RMS Compressor with selectable ratio, variable knee and Hold Time.

4 Additional All-Pass filter up to 2nd order per output channel

Adjustable Delay time up to 10 ms for input and output channels

Input channel includes a Noise Gate function, Pink/White noise generator, sophisticated Dynamic Loudness function and a High-Pass filter with slopes from 6dB/Octave up to -48dB/Octave including Butterworth, Bessel, Linkwitz-Riley

Network Connection

Rs485 connection for system setup, monitoring and control via fully manageable remote PC software

Control

Simultaneous control up to 32 units via PC software

8 Preset Selection by using rotary encoder switch

Security Lockout

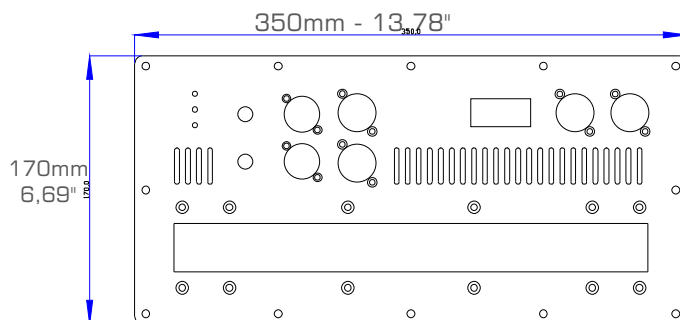

Power & Amplifier Sections

Number of Channels	----- 2
Max Output Power @ 8 ohms	----- 2 x 400W; 1 x 1400W (Bridge)
Max Output Power @ 4 ohms	----- 2 x 800W
Output Circuitry	----- Class D - full bandwidth PWM modulator with ultra low distortion
Output Voltage	----- 80 Vp / 160 Vpp (unloaded) / Bridged 160 Vp / 320 Vpp (unloaded)
THD+N	----- <0.01% (20 Hz - 20 kHz, 8Ω load, 3dB below rated power)
Signal To Noise Ratio	----- >102 dB (A-weighted, 20 Hz - 20 kHz, 8Ω load)
Frequency Response	----- 20 Hz - 20 kHz ± 0,15 dB (8Ω load, 1 dB below rated power)
Damping Factor	----- >1000 (8Ω load, 1kHz and below)
Power Supply	----- Switch mode power supply with PFC (Power Factor Correction) and integral standby converter
Operating Range	----- Universal Mains, 85-265V
Consumption / Current draw and	----- 25 W / -A / 85.35 BTU/h (Idle)
Thermal dissipation @ 230 V	----- 335 W / -A / 460.9 BTU/h (l/8 max. power@4Ω)
Protections	----- Over-Current, Over/Under Voltage, Output DC and Over-Temperature
Maximum Input/Output Level	----- +12dB

Audio

Analog Input	----- 1 x XLR electronically balanced, +12dB
Analog Output	----- 1 x XLR electronically balanced (Link)
AD & DA Converters	----- Cs42528 24bit

DSP & Processing

DSP Engine	----- MARANI M704
DSP Resolution	----- 24bit (data) x 24 bit (coeff.), 54bit accumulation registers, 96 bit precision on intermediate processing data
Parametric Equalization	----- 5 filters per input channel; 7 filters per output channel
Filter Type	----- Bell, Low/High Shelving variable Q
Filter Gain	----- From -12dBu up to +12dBu by 0.5dBu resolution steps
Center Frequency	----- Selectable with a 1Hz resolution step from 20Hz up to 20kHz
Bell Filter Q/BW	----- Q from 0.5 up to 10 by 0.1 resolution steps
Low/High Shelving Filter Q	----- Q from 0.5 up to 3 by 0.1 resolution steps
Crossover section HPF/LPF	----- Butterworth 6/12/18/24/48dB per octave; Linkwitz-Riley 12/24/36/48dB per octave; Bessel 12/24dB per octave. Filter resolution 1Hz
OutPut RMS Compressor	----- Drive from -12 to +6dBu; Threshold from -18dBu up to +12dBu; Knee 0~100%; Ratio from 2:1 to 100:1; Attack time from 5ms up to 500ms; Release time from 40ms up to 1000ms (10ms resolution).
Input RMS Compressor	----- Make Up from -12 to +12dBu; Threshold from -18dBu up to +12dBu; Knee 0~100%; Ratio from 2:1 to 100:1; Attack time from 5ms up to 500ms; Release time from 40ms up to 1000ms.
Clip Limiter	----- Input Hold-Time up to 10sec. Bypass, soft and Hard Threshold
Delay	----- 10 ms 10.4us increment/decrement steps per channel
Slipt Band X-over(only High Band)	----- Freq from 5kHz to 20kHz step 1Hz resolution, slope: bypass, 1st order butterworth and 2nd order Linkwitz-Riley
Ground Noise	----- -86 dBu

General

User Preset	----- 8
Panel	----- 2x8 Alphanumeric LCD Display GAIN pot. -30dBu ~ 0dBu PRESET EQ Rotary encoder switch Green LED (Power); Yellow LED (Limit); Blue LED (Signal presence) 1 x XLR female connector (Input) 1 x XLR male connector (Link Output) 2 x RJ45 EtherCon connector (M-LAN Rs485) 2 X Locking PowerCON® 20A: AC Mains (blue) - AC Link (white)
Dimensions	----- 13,78"x 3"x 6,69" (350x75x170mm)
Weight, Net / Shipping	----- 5.84 lbs (2.65 Kg) / 7.72 lbs (3.5 Kg)

Specifications subject to change without notice

Designed in Italy Assembled in China